

## Investigation of the Effects of Repeated Invasive Interventions on Physical, Motor and Cognitive Function in Neonatal Rats

Canberk YILMAZ<sup>1</sup>, Pembe KESKİNOĞLU<sup>2</sup>, Serap CİLAKER MICİLİ<sup>3</sup>, Osman YILMAZ<sup>4\*</sup> and Defne ENGÜR<sup>5</sup>

<sup>1</sup>Health Sciences University, Tepecik Research and Training Hospital, Child Health and Diseases, İzmir, Türkiye

<sup>2</sup>Dokuz Eylül University Faculty of Medicine, Department of Biostatistics, İzmir, Türkiye

<sup>3</sup>Dokuz Eylül University, Faculty of Medicine, Department of Histology, İzmir, Türkiye

<sup>4</sup>Dokuz Eylül University, Faculty of Medicine, Experimental Animals Laboratory, İzmir, Türkiye

<sup>5</sup>Health Sciences University, Tepecik Research and Training Hospital, Child Health and Diseases, İzmir, Türkiye

**Citation:** YILMAZ C, et al., Investigation of the Effects of Repeated Invasive Interventions on Physical, Motor and Cognitive Function in Neonatal Rats. *J M Med Stu* 2026; 3(1): 234-244. DOI: doi.org/10.51219/JMMS/canberk-yilmaz/58

**Received:** 26 February, 2026; **Accepted:** 12 March, 2026; **Published:** 14 March, 2026

**\*Corresponding author:** Osman YILMAZ, Dokuz Eylül University, Faculty of Medicine, Experimental Animals Laboratory, İzmir, Türkiye, E-mail: osman.yilmaz@deu.edu.tr

**Copyright:** © 2026 YILMAZ C, et al., this is an open-access article distributed under the terms of the Creative Commons Attribution License, which permits unrestricted use, distribution and reproduction in any medium, provided the original author and source are credited.

### ABSTRACT

Preterm infants undergo a highly critical and stressful intensive care process in neonatal intensive care units (NICUs) to sustain life. During this period, they are exposed daily to numerous repeated painful invasive procedures and the associated stress. However, current knowledge regarding the long-term consequences of early-life pain and stress exposure in preterm infants remains limited, underscoring the need for further investigation.

The present study aimed to investigate the effects of pain and stress induced by an experimental model of repeated invasive procedures-designed to mimic the neonatal intensive care experience of preterm infants-on early physical growth and motor development, as well as on later behavioral outcomes and learning performance in neonatal rats. A total of 16 neonatal Wistar albino rats were included in this study. The experimental group (n = 8) was subjected to repeated invasive procedures from postnatal day (PN) 1 to PN10. Specifically, ten invasive stimulations were administered daily at 1-hour intervals using a sterile 24-gauge branula needle to the skin of the neck, forelimbs and thoracic region.

Early physical development parameters-including body weight gain, timing of eye opening, ear unfolding and tooth eruption-were assessed in both the intervention and control groups. Motor reflex development (crawling, walking, cliff avoidance, grasping reflex, righting reflex and other motor tests) was also evaluated. In later life, behavioral performance, learning capacity, motor balance, pain responses and brain histopathological findings were examined and compared between groups. Neonatal rats that were not subjected to invasive procedures exhibited significantly greater body weight gain compared to those exposed to repeated interventions (p < 0.05). No significant differences were observed between groups in terms of motor reflex development tests (p > 0.05).

In young adulthood, rats exposed to repeated invasive procedures demonstrated increased fear- and anxiety-related behaviors compared to controls. Additionally, attention, learning and memory performance were significantly impaired in the intervention

group ( $p < 0.05$ ). Social interaction levels were significantly higher in the control group than in the intervention group during young adulthood ( $p < 0.05$ ).

Rats exposed to repeated invasive procedures showed delayed responses to painful stimuli and exhibited increased pain tolerance compared to controls ( $p < 0.05$ ).

Histopathological evaluation in young adulthood revealed significantly higher numbers of apoptotic cells in the hippocampal CA1 region, dentate gyrus, parietal cortex, prefrontal cortex and retrosplenial cortex in the intervention group compared to controls ( $p < 0.001$ ).

In conclusion, the findings of this study indicate that pain-induced stress resulting from repeated invasive procedures in preterm neonatal rats adversely affects physical growth, motor development, behavioral outcomes and learning performance.

**Keywords:** Preterm neonatal rats, Repeated invasive procedures, Pain, stress, Anxiety, Physical development, Behavioral outcomes, Learning performance

## 1. Introduction

According to the World Health Organization, approximately 15 million infants are born preterm each year worldwide and this number continues to rise<sup>1</sup>. Preterm infants particularly those born between 24 and 32 weeks of gestation require intensive and specialized care in neonatal intensive care units (NICUs) to survive. During this life-saving care process, preterm infants are exposed daily to repeated procedural pain and the associated stress. Although preterm infants possess the necessary nociceptive circuitry to perceive pain, these systems are not yet fully functionally mature<sup>2,3</sup>. Infants born before 35 weeks of gestation demonstrate central sensitization in response to repeated invasive painful stimuli<sup>4-8</sup>. Neonatal pain responses vary depending on gestational age, sleep-wake state and the intensity and duration of the invasive procedure<sup>9,10</sup>. Clinicians often face challenges in accurately recognizing and effectively managing pain in preterm infants. Pharmacological treatments are not considered ideal for routine pain management in this population<sup>11</sup>. Although non-pharmacological strategies are recommended as first-line approaches, invasive procedures in NICUs are frequently performed without adequate supportive interventions<sup>12</sup>.

Stress hormones are glucocorticoids that regulate gene transcription in both the body and the brain (cortisol in humans and corticosterone in rodents)<sup>13</sup>. In physiologically immature neonates, prolonged activation of the hypothalamic-pituitary-adrenal (HPA) axis may therefore lead to long-term alterations in hormonal (e.g., growth and glucocorticoid regulation), physiological (e.g., metabolic and immune) and behavioral systems (e.g., anxiety and depression)<sup>14,15</sup>.

Despite the high number of invasive procedures required during their stay in the NICU, preterm infants often exhibit lower-than-expected cortisol levels<sup>16</sup>. In an experimental study, rat offspring exposed to prolonged maternal separation during early life demonstrated reduced hippocampal glucocorticoid receptor expression and increased production of corticotropin-releasing factor (CRF), adrenocorticotropic hormone (ACTH) and corticosterone in adulthood<sup>17</sup>. Prolonged stress exposure in preterm infants has also been associated with alterations in glucocorticoid receptor expression in the hippocampus and prefrontal cortex, which may contribute to long-term structural and functional changes in the brain<sup>18</sup>.

The neonatal brain contains two particularly vulnerable cell populations: subplate neurons and pre-oligodendrocytes.

Pain-related stress in the neonatal period may disrupt pre-oligodendrocytes cells that ensheath axons prior to differentiation into myelin-producing oligodendrocytes thereby interfering with normal myelination<sup>19</sup>. Subplate neurons are among the earliest-generated neurons in the mammalian cerebral cortex and represent the first cortical neurons to receive excitatory synaptic input from thalamic axons, forming transient connections between thalamic projections and their ultimate cortical targets<sup>20-22</sup>.

During early development, N-methyl-D-aspartate (NMDA) receptors play a critical role in pain signal transmission. Compared to NR2B, the NR2A receptor subunit becomes developmentally more active. Repeated procedural pain may induce excessive glutamate release and calcium influx, leading to excitotoxicity and apoptosis of subplate neurons<sup>23-25</sup>. The immature state of subplate neurons renders them particularly vulnerable to reactive oxygen and nitrogen species, as well as to cytokines released by activated microglia<sup>26-31</sup>. Procedural pain triggers both oxidative stress and inflammatory responses, potentially impairing myelination processes<sup>32,33</sup>.

Procedural pain and stress experienced in the NICU have been shown to be associated with abnormal brain development in very preterm infants up to term-equivalent age<sup>34,35</sup>. Consistent with these findings, animal models have demonstrated that both inflammatory pain and repeated injections increase apoptosis in the neonatal rat brain<sup>36,37</sup>. Moreover, the impact of neonatal pain-related stress appears to extend beyond early life, influencing long-term neurodevelopmental outcomes<sup>34,38</sup>.

In a cohort study, greater exposure to skin-breaking procedures in the NICU was associated with reduced cortical gray matter thickness in 21 of 66 cerebral regions at 7 years of age, predominantly affecting the frontal and parietal lobes<sup>39</sup>. In very preterm infants, stress related to invasive pain has also been linked to alterations in spontaneous brain activity at school age and was negatively correlated with visual-perceptual abilities<sup>40</sup>.

Although advances in neonatology have significantly improved survival rates among preterm infants, more than one-quarter of survivors experience moderate to severe neurodevelopmental impairments. In preterm infants, an imbalance between pain-excitatory and inhibitory mechanisms results in increased nociceptive signaling within the central nervous system, contributing to excitotoxicity, oxidative stress and inflammation in vulnerable cell populations<sup>41</sup>.

During their NICU stay, preterm infants are exposed to an average of approximately 10 invasive and stressful procedures per day, amounting to nearly 200 painful procedures in total. Other reports indicate that neonates in the NICU undergo between 7 and 17 painful procedures daily<sup>42,43</sup>. Furthermore, long-term cohort studies have shown that neonates exposed to repeated painful stimuli exhibit significantly lower intelligence, motor performance and behavioral regulation at school age compared to term-born peers<sup>44</sup>. Greater exposure to invasive pain during the preterm period has also been associated with poorer cognitive and motor outcomes, as well as increased anxiety- and depressive-like behaviors later in life<sup>39,45,46</sup>.

In light of the aforementioned literature, prolonged exposure to repeated procedural pain appears to exert significant developmental effects on the neonatal brain. Stress associated with neonatal pain may adversely influence brain maturation and these neurodevelopmental consequences seem to persist throughout life.

The aim of the present study was to investigate the effects of pain induced by repeated invasive procedures in a preterm neonatal rat model on early physical growth and motor reflex development, as well as on long-term pain tolerance responses, motor coordination and cognitive functions.

## 2. Materials and Methods

**Animals and experimental design;** This study was conducted following approval from the Dokuz Eylul University Animal Experiments Local Ethics Committee (Protocol No: 09/2022). A total of 16 neonatal Wistar albino rats born to three different dams were obtained from the Multidisciplinary Experimental Research Laboratory of Dokuz Eylul University Faculty of Medicine.

Offspring from each dam were randomly assigned to either the invasive intervention (experimental) group or the

non-intervention (control) group. Dams and their litters were housed in standard rodent cages under controlled environmental conditions (12-hour light/12-hour dark cycle, temperature 22-25°C, relative humidity 50-60%). Dams were fed standard rodent pellet chow ad libitum.

Neonatal rats are born weighing approximately 4-5 g. The first 10 postnatal days are considered developmentally comparable to the premature period in humans. In rats, postnatal days 1-21 correspond to the lactation period; days 32-48 represent sexual maturation; days 49-70 correspond to adolescence; and after day 100, rats are considered adults<sup>47</sup>.

Neonatal rats were selected as the experimental model because the first 10 postnatal days reflect a developmental stage comparable to prematurity in humans, thereby enabling simulation of the clinical conditions experienced by preterm infants. In the present study, behavioral, learning and memory assessments were conducted between postnatal days 30 and 60, corresponding to the human childhood/school-age developmental period.

The timeline of repeated invasive procedures and the schedule of experimental assessments are presented in **(Figure 1)**:

### 2.1. Experimental groups and study design

- **Control group (no invasive intervention) (n = 8):** Offspring were separated from their dams 10 times daily between postnatal days (PN) 1 and 10. No invasive procedures were performed during these separations.
- **Experimental group (repeated invasive intervention) (n = 8):** Offspring were separated from their dams 10 times daily between PN1 and PN10. During each separation, invasive procedures were administered at 1-hour intervals using a 24-gauge needle to three different skin regions (neck, forelimb and thoracic area).

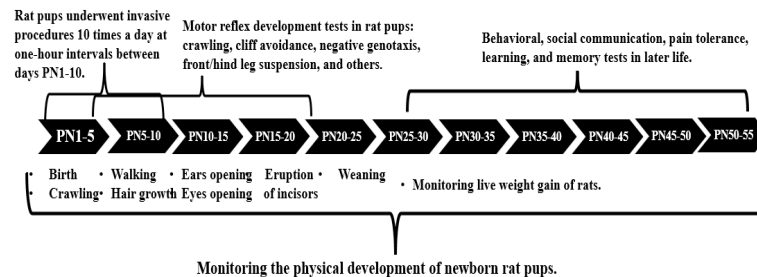

**Figure 1:** Timeline of Repeated Invasive Procedures and Behavioral Assessments.

**Repeated Invasive Procedure in Neonatal Rats;** Repeated invasive procedures were administered to neonatal rats beginning on postnatal day 1. Offspring were separated from their dams and placed on a cloth warmed to mimic maternal body temperature. Invasive stimulation was performed at 1-hour

intervals using a sterile 24-gauge branula needle inserted into the skin of the neck, forelimb and thoracic regions **(Figure 2)**. Each procedure lasted approximately 1-2 minutes.

All procedures were conducted daily between 08:00 and 17:00 under standardized experimental conditions.



**Figure 2:** Repeated Invasive Procedures in Neonatal Rats.

The experimental protocol was designed in consideration of the average length of stay of preterm infants in neonatal intensive care units<sup>48,49</sup>. During each session, three invasive stimulations were administered to each neonatal rat, targeting three different anatomical regions: the neck, forelimb and lateral thoracic wall.

Because the procedures were repeated 10 times daily at 1-hour intervals, each offspring received a total of 30 invasive stimulations per day. As the intervention period lasted for 10 consecutive days, each neonatal rat was exposed to a total of 300 invasive procedures.

Given that one postnatal day in rats is considered approximately equivalent to 19 human days, the 10-day intervention period was assumed to simulate approximately 5–6 months of NICU exposure in a preterm infant.

Invasive procedures were performed using a sterile 24-gauge branula needle inserted subcutaneously. During handling, offspring were touched using gloved hands and a clean cloth. Care was taken to avoid skin injury and bleeding. If minor bleeding occurred at the intervention site, it was gently cleaned with sterile cotton before the offspring were returned to their dams. This precaution was taken to prevent the potential development of cannibalistic behavior in the dams.

### 3. Assessment Methods of Repeated Invasive Procedures in Preterm Neonatal Rats

#### 3.1. Evaluation of early-life effects

- **Body weight monitoring:** Neonatal rats that completed the first 24 hours after birth were considered postnatal day 1. Body weights of both intervention and control groups were measured daily at the same time to monitor weight gain.
- **Assessment of physical development:** Physical developmental milestones were recorded in both groups, including ear unfolding (detachment of the pinna from the head), fur development, eye opening, eruption of incisors and transition to solid food.

- **Assessment of motor reflex development:** To evaluate the potential effects of repeated invasive procedures on motor reflex development, standardized motor reflex tests were performed according to previously published protocols<sup>50,51</sup>. Assessments were conducted once daily between postnatal days 3 and 18, between 09:00 and 12:00 a.m.

All motor tests were video-recorded and independently scored by two researchers blinded to group allocation.

Beginning on postnatal day 3, the following motor reflexes were evaluated: crawling, forelimb and hindlimb grasp reflex, forelimb and hindlimb suspension, cliff avoidance, negative geotaxis, auditory startle response, accelerated righting reflex and grip strength.

The timing of motor developmental assessments was determined based on the literature (Figure 3).

#### 3.2. Evaluation of long-term effects

Assessment of Learning, Memory and Behavior; To evaluate the long-term effects of repeated painful invasive procedures on learning, memory and behavior, offspring were subjected to the open field test (PN32-33), Y-maze test (PN35-38) and social interaction test (PN43-44).

Open Field Test: The open field test was performed on postnatal days 32-33 to assess exploratory behavior and anxiety-like responses following repeated painful interventions. The open field test is widely used to evaluate both anxiety-related behavior and locomotor activity.

Behavioral recordings and analyses were conducted using the Noldus video tracking system (Figure 4). Reduced time spent in the center of the arena and increased time spent in the periphery or corners were considered indicators of anxiety-like behavior<sup>52,53</sup>.

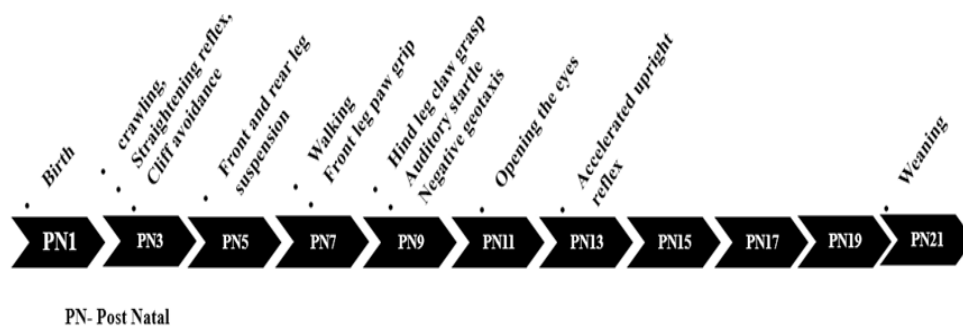

Figure 3: Motor Reflex Tests in Neonatal Rats and Their Time Schedule.

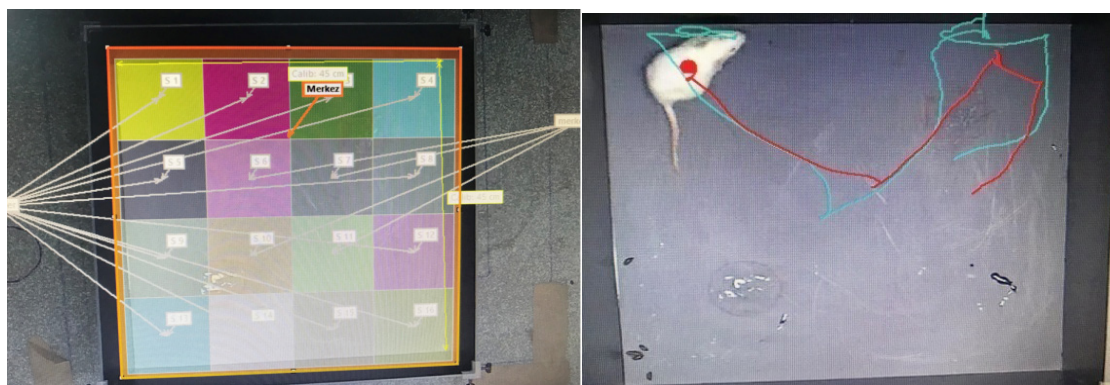

Figure 4: Open Field Test Arena.

**Y-Maze Test:** The Y-maze test was conducted on postnatal days 35-38 to assess short-term memory, spatial exploration and attention<sup>54</sup>. The apparatus consisted of three arms (15 cm arm width × 50 cm arm length × 30 cm wall height) constructed from black polypropylene.

In animals with intact prefrontal cortical function, there is a natural tendency to explore a novel arm rather than returning to previously visited arms.

During the training phase, one arm was closed and each rat was allowed to explore the two open arms for 10 minutes daily at the same time of day. On the test day (day 4), the previously closed arm was opened and the number of entries into the novel and familiar arms, as well as the time spent in each arm, were recorded over a 10-minute test period.

Behavioral data were recorded and analyzed using the Noldus video tracking system. The maze was cleaned with 70% ethanol after each trial. Time spent in arms A, B and C was calculated from the video recordings. The duration of time each rat spent in arms A, B and C was calculated from the recordings (**Figure 5**).

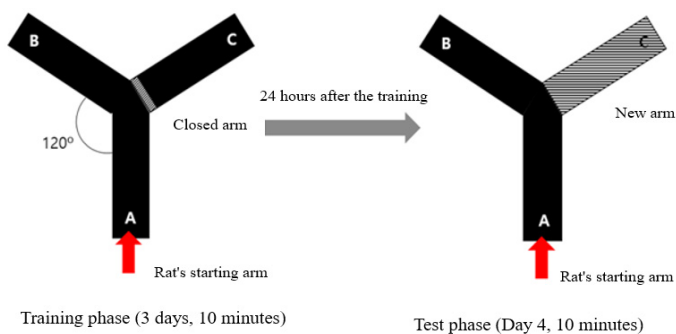

**Figure 5:** Y Maze Test Arena.



**Figure 6:** Social interaction Test Arena.

Each rat was gently restrained using a towel and approximately 3–4 cm of the distal tail was immersed in a water bath maintained at  $52 \pm 0.5^\circ\text{C}$ . A stopwatch was activated at the moment of tail immersion. The latency (in seconds) to tail withdrawal or flicking was recorded as an index of thermal pain sensitivity<sup>56,57</sup>.

**Formalin Test;** The formalin test was conducted on postnatal day 53 to assess responses to chemically induced nociceptive stimulation. Prior to testing, rats were habituated to a transparent plexiglass observation chamber for 30 minutes to reduce novelty-induced stress.

To control for potential circadian influences on nociceptive and analgesic sensitivity, all procedures were performed between 10:00 and 13:00. Each rat received a subcutaneous injection of

**Social Interaction Test:** The social interaction test was performed on postnatal days 43-44, approximately five weeks after repeated invasive procedures<sup>55</sup>. The test arena ( $90 \times 45.5 \times 40$  cm) was divided into three equal compartments using plexiglass walls (**Figure 6**). The apparatus consisted of a central chamber and two side chambers accessible through sliding doors.

Prior to testing, stimulus rats of similar age were habituated for two days (10 minutes per day) in small wire cages ( $20 \times 14 \times 13$  cm) placed within the test arena.

On the test day, the experimental rat was initially placed in the central compartment with the doors closed and baseline behavior was recorded for 5 minutes. After this period, an unfamiliar, same-sex conspecific (previously habituated to the cage) was placed in a wire cage in one of the side chambers, while an empty cage was placed in the opposite chamber. The doors were then opened and the experimental rat's behavior was recorded for 10 minutes.

Following this phase, the experimental rat was returned to the central chamber. A novel, same-sex unfamiliar rat was placed in the previously empty cage and behavior was recorded for an additional 10 minutes after reopening the doors.

All behavioral recordings were performed and analyzed using the Noldus video tracking system. The arena was cleaned with 70% ethanol after each trial (**Figure 6**).

### 3.3. Assessment of responses to noxious stimuli

**Hot Water Tail-Flick Test;** The hot water tail-flick test was performed on postnatal days 47–49 to evaluate thermal nociceptive responses following repeated painful invasive procedures. All tests were conducted between 10:00 and 13:00 to minimize circadian variability.

0.05 mL of 2.5% formalin into the plantar surface of the left hind paw using a 24-gauge branula needle. Immediately following injection, a stopwatch was started.

The number of paw withdrawals and licking behaviors during the first 5 minutes following injection was recorded as indicators of nociceptive response<sup>58,59</sup>. Behavioral scoring was performed by an observer blinded to group allocation. To minimize data loss, behavioral responses were video-recorded and independently monitored by at least two observers.

**Assessment of Balance and Motor Coordination;** Balance and motor coordination were evaluated on postnatal days 50–52 to determine the effects of pain- and stress-related exposure on motor performance. All assessments were conducted between 10:00 and 13:00.

For the motor balance test, a wooden beam measuring 105 cm in length, 4 cm in width and 3 cm in height was elevated 80 cm above the floor. One end of the beam was designated as the starting point, while a platform containing the rat's home cage was positioned at the opposite end (Figure 7). A line was marked 20 cm from the starting point and the rat was placed



within this designated starting area, facing toward its home cage.

The stopwatch was initiated immediately upon placement of the rat. The time required for the rat to traverse the beam and reach the home cage platform with all four paws was recorded as the latency to completion<sup>60</sup>.

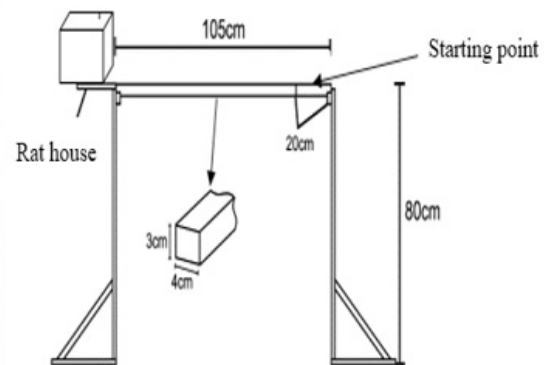

**Figure 7:** Rat Motor Balance Test Bar and its Characteristics.

**Brain Histopathological Evaluation;** On postnatal day 54, approximately eight weeks after repeated invasive procedures, rats were anesthetized with ketamine (50 mg/kg) and xylazine (10 mg/kg) and positioned supine on a surgical platform. Following sternotomy, the thoracic cavity was opened.

While cardiac activity was maintained, the right atrium was incised to allow blood drainage and 30–40 mL of physiological saline was perfused through the left ventricle to remove circulating blood from the vascular system and tissues. Subsequently, transcatheter perfusion was performed with 30–40 mL of 10% formaldehyde to achieve whole-body fixation.

After perfusion, craniotomy was performed and the brain and cerebellum were removed en bloc. Histopathological evaluation focused on the hippocampal CA1 region, dentate gyrus, parietal cortex and prefrontal cortex.

**Statistical Analysis;** Statistical analyses were performed using the Statistical Package for the Social Sciences (SPSS) software (version 24.0). Descriptive statistics were expressed as mean  $\pm$  standard deviation (SD).

Normality of data distribution was assessed using the Shapiro–Wilk test. For comparisons between groups, the Kruskal–Wallis test was used for non-parametric data and post hoc pairwise comparisons were performed using the Mann–Whitney U test when appropriate. Independent-samples t-tests were used to compare means between two groups when parametric assumptions were met.

All models constructed for six variables satisfied parametric assumptions. Statistical significance was defined as  $p < 0.05$ .

## 4. Results

**Body Weight Changes;** Comparison of body weight gain between the experimental and control groups demonstrated higher weight gain in the control group between postnatal days (PN) 4 and 18. A statistically significant difference in mean body weight between the groups was observed on PN8 ( $p < 0.05$ ).

Although body weight gain remained higher in the control group after PN18, statistical significance was no longer

observed. After PN40, the difference in body weight between the two groups was no longer evident.

**Assessment of Physical Development;** Physical developmental parameters, including timing of ear unfolding, separation of toes, eruption of upper and lower incisors, fur development and eye opening, were compared between the experimental and control groups. No statistically significant differences were observed between groups for any of these developmental milestones.

**In-Cage Sibling Interaction Behavior;** Offspring exposed to repeated invasive procedures exhibited increased activity levels and more aggressive and competitive behaviors toward both intervention-exposed and non-exposed littermates within the cage environment. Prolonged fighting episodes and dominance-related behaviors were more frequently observed in the experimental group compared with controls.

**Abnormal Vocalization;** Abnormal vocalizations were observed in rats exposed to repeated invasive procedures beginning on the second and third days of the experiment when handled manually. Following separation from their dams for interventions and motor testing, these animals produced intense vocal sounds, showed escape-related reactions and increasingly attempted to protect the intervention sites.

Notably, despite having unopened eyes during this developmental period, intervention-exposed offspring demonstrated clear protective responses toward the stimulated body regions.

**Motor Reflex Development;** Motor reflex development was evaluated to determine the effects of repeated invasive procedures. No significant differences were detected between experimental and control groups in crawling onset, righting reflex, cliff avoidance, forelimb and hindlimb grasp reflexes, forelimb and hindlimb suspension tests, walking onset, grip strength, hind paw placement, auditory startle response, negative geotaxis, eye opening time or accelerated righting reflex performance.

### 4.1. Learning, memory and behavioral assessment results

**Open Field Test;** The open field test was performed to evaluate the effects of repeated invasive procedures on anxiety-

like behavior and locomotor activity. The mean values, standard deviations and p-values of open field test variables for the experimental and control groups are presented in **(Table 1)**.

According to the open field test results, rats in the control group demonstrated a higher frequency of entries into the central zone and spent significantly more time in the center compared with the experimental group. Comparison of time spent in the central area revealed a statistically significant difference between groups ( $p < 0.05$ ).

In contrast, rats exposed to repeated invasive procedures showed a greater preference for the peripheral areas of the open field arena.

**Social Interaction Test;** The social interaction test was conducted on postnatal days 43–44 to assess the effects of repeated invasive procedures on social behavior. Comparison of sociability and social preference parameters demonstrated significantly higher sociability scores in the control group compared with the experimental group ( $p < 0.05$ ) **(Table 1)**.

**Y-Maze Test;** The Y-maze test was performed to evaluate learning and memory performance. Rats in the control group exhibited significantly higher numbers of entries into the novel arm and spent more time in the novel arm compared with rats exposed to repeated invasive procedures ( $p < 0.05$ ).

Mean values, standard deviations and p-values of Y-maze test variables according to study groups are presented in **(Table 1)**.

**Table 1:** Learning, Memory and Behavioral Assessment Outcomes in Experimental and Control Groups.

Tests	Variables	Control group (Mean ±SD)	Experimental group (Mean±SD)	P*
Open Field	Frequency of entering the center	7,7±5,5	4,8±2,8	0,034
	Time spent at the center (seconds)	16,8±9,5	10,2±6,3	0,045
	Frequency of periphery entry	5,7±5,5	6,6±2,9	0,356
	Peripheral presence time (seconds)	287,1±9,4	332,8±6,3	0,250
Social Interaction	Social skills score	0,32±0,3	0,18±0,26	0,043
	Social preference score	0,09±0,41	0,05±0,53	0,538
Y Maze	Time spent on the new arm (sec.)	275,9±114,9	169,3±150,1	0,032
	New arm input count	9,13±3,36	5,29±1,49	0,029

\*T-test.

**4.2. Assessment of responses to painful stimuli**

**Formalin Test;** The formalin test was performed to compare nociceptive responses between rats exposed to repeated invasive procedures and control animals. Rats in the experimental group exhibited fewer hind paw withdrawal and licking behaviors following formalin injection compared with the control group. Comparison of hind paw withdrawal counts revealed a

statistically significant difference between the groups ( $p < 0.05$ ) (Table 2).

**Hot Water Tail-Flick Test;** The hot water tail-flick test was conducted to evaluate responses to thermal nociceptive stimulation. Rats exposed to repeated invasive procedures demonstrated longer tail withdrawal latencies compared with control rats. Comparison of tail withdrawal times between the two groups showed a statistically significant difference ( $p < 0.05$ ) **(Table 2)**.

**Table 2:** Results of the Formalin Test and Hot Water Tail-Flick Test.

Tests	Variables	Control group	Experimental group	P*
Formalin	Rear Leg Pull Count Median (Min-Max)	36(23-56)	29 (13-47)	0,025
Hot Water Tail Immersion	Tail Pulling Time (seconds) Average ± SS	4,7 ± 0,6	5,2 ± 0,3	0,033

\*MWU -test

**4.3. Balance and motor coordination assessment results**

The effects of repeated invasive procedures on balance and motor coordination in later life were evaluated in preterm neonatal rats. Rats in the control group crossed the balance beam in a shorter time compared with rats in the experimental group

**(Table 3)**.

Statistical comparison between the two groups revealed a significant difference in performance ( $p < 0.05$ ). In addition, rats in the experimental group were observed to fall from the balance beam more frequently during testing.

**Table 3:** Balance and Motor Coordination Test Results.

Motor Balance Test	Control group	Experimental group	P*
Time to Cross the Balance Bar (seconds) Average ± SS	16,2 ± 3,3	7,3 ± 0,9	0,003*

\*T -test

**4.4. Brain histopathological evaluation results**

Histopathological analyses were performed to evaluate brain regions associated with learning, memory, behavior and pain processing following repeated invasive procedures. The effects

of repeated invasive interventions on apoptotic cell counts were examined in the hippocampal CA1 region, dentate gyrus, parietal cortex and prefrontal cortex.

Rats exposed to repeated invasive procedures demonstrated

higher numbers of apoptotic cells in the hippocampal CA1 region, dentate gyrus, parietal cortex and prefrontal cortex compared with control animals.

The mean apoptotic cell counts, standard deviations and statistical comparisons between the experimental and control groups are presented in (Table 4). Representative histopathological images demonstrating apoptotic neuron density in the hippocampal CA1 region, dentate gyrus, parietal cortex and prefrontal cortex are shown in (Figure 8).

**Table 4:** Apoptotic Cell Counts in Different Brain Regions.

Brain Region	Control group (Mean±SD)	Experimental group (Mean±SD)	P*
Hippocampus CA 1 apoptotic cell numbers	1,33±0,56	10,83±4,3	0,001
Gyrus dentatus apoptotic cell numbers	2,28±0,80	13,61±8,06	0,001
Parietal cortex apoptotic cell numbers	10,28 ±5,11	26,01 ±12,43	0,001
Prefrontal cortex apoptotic cell numbers	6,67 ±2,28	14,83 ±6,29	0,001

\*T test

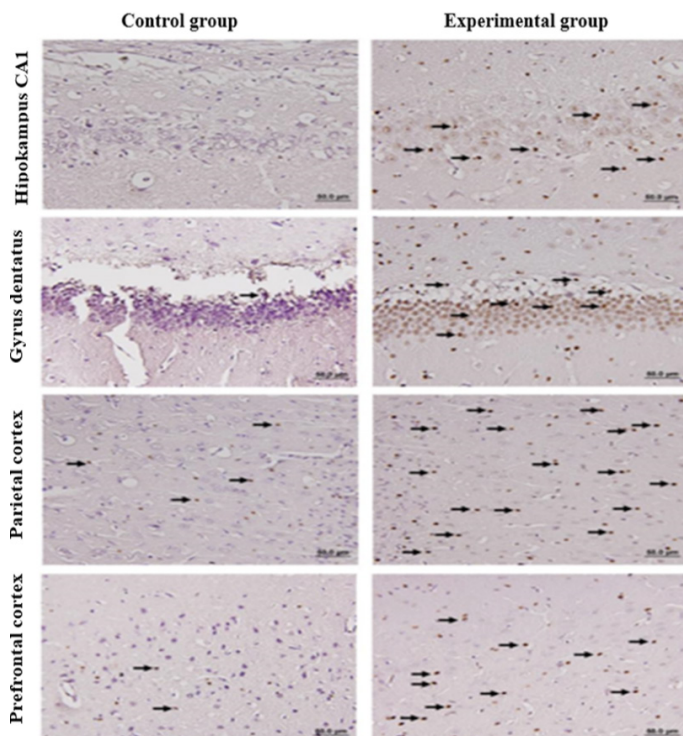

**Figure 8:** Histopathological Evaluation of Brain Regions and Apoptotic Cells.

## 5. Discussion

**Effects on Body Weight Gain;** In the present study, pain- and stress-related exposure caused by repeated invasive procedures negatively affected body weight gain in preterm neonatal rats. Offspring exposed to repeated interventions exhibited lower weight gain compared with controls, with the difference reaching statistical significance particularly on postnatal day 8 ( $p < 0.05$ ). However, during later developmental stages when invasive procedures were discontinued, the difference in body weight gradually diminished and was no longer statistically significant. These findings are consistent with the study conducted by Anand et al., in which repeated invasive stimulation was associated with reduced weight gain in neonatal rats<sup>61</sup>. Our

results suggest that repeated procedural pain and stress experienced during early life may contribute to growth impairment, a condition that may also be relevant to preterm infants exposed to frequent invasive procedures in neonatal intensive care units.

**Effects on Physical Development;** Repeated invasive procedures and the associated pain-related stress did not produce significant alterations in physical developmental milestones, including fur development, ear unfolding, eye opening or eruption of incisors. A review of the literature indicates a lack of studies systematically evaluating physical developmental parameters following repeated invasive procedures in neonatal rat models. Therefore, the present findings contribute additional information regarding the potential dissociation between somatic developmental milestones and early-life pain exposure.

**Behavioral Responses and Vocalization in Preterm Neonatal Rats;** Despite having unopened eyes during the early postnatal period, rats exposed to repeated invasive procedures appeared to recognize and respond to painful needle stimulation beginning approximately on the second or third day of exposure. These animals demonstrated escape-related behaviors during handling and produced pronounced vocalizations when separated from the experimenter or subjected to procedures. The observation that neonatal rats exhibited protective responses and increased vocalization suggests that repeated painful experiences may be encoded even during very early developmental stages. Such vocalizations may represent instinctive defensive behaviors or communicative warning signals aimed at increasing safety within the litter environment. To our knowledge, similar behavioral observations related to early procedural pain exposure have not been extensively reported in previous studies, highlighting a potentially novel contribution of the present work.

**Effects of Repeated Invasive Procedures on In-Cage Social Behavior;** Repeated invasive procedures appeared to influence both dam-offspring interactions and sibling relationships within the home cage environment. Intervention-exposed offspring demonstrated increased aggressive and competitive behaviors compared with non-exposed littermates. These animals were observed to disturb both their dams and siblings more frequently. These findings may indicate that prolonged exposure to pain and stress during the premature period contributes to behavioral dysregulation later in development. Although extensive research has examined neurodevelopmental outcomes following neonatal pain exposure, studies specifically evaluating naturalistic social interactions within the home cage remain limited. In this respect, the present study may provide a novel behavioral perspective.

**Effects of Repeated Invasive Procedures on Motor Reflex Development;** In the current study, repeated invasive procedures administered during the first 10 postnatal days did not significantly affect motor reflex development in neonatal rats. Comprehensive assessment of multiple motor reflex parameters revealed comparable developmental trajectories between experimental and control groups. A review of the literature suggests that studies evaluating motor reflex development following repeated neonatal invasive exposure in such a comprehensive manner are limited. Therefore, our findings may help address an important gap in the existing literature.

**Effects of Repeated Invasive Procedures on Behavior, Learning and Memory;** The findings of the present study demonstrate that pain and stress induced by repeated invasive proce-

dures during the premature period lead to increased fear- and anxiety-like behaviors and negatively affect attention, learning, memory performance and motor balance coordination in later life. These results support the hypothesis that procedural pain and stress experienced by preterm infants in neonatal intensive care units may contribute to neurodevelopmental disturbances with long-lasting neurobehavioral consequences. Previous experimental and clinical studies provide substantial evidence supporting these findings. Vinall et al. reported that repeated or persistent pain exposure during the neonatal period increases neuronal apoptosis and is associated with anxiety-like behaviors in adulthood. Furthermore, pain-related stress experienced in the NICU environment has been shown to alter spontaneous brain activity at school age and negatively influence visual-perceptual development in preterm children<sup>61</sup>. Similarly, Ranger et al. demonstrated that the cerebellum of preterm infants is particularly vulnerable to painful stimuli during early life and exposure to neonatal procedural pain was associated with reduced cerebellar vermis volume at seven years of age. Importantly, this structural alteration was linked to poorer working memory performance<sup>62</sup>. In another study, Cook et al. reported a negative association between increased exposure to invasive procedures and later language performance in preterm infants<sup>63</sup>. Large cohort studies conducted by Selvanathan et al. further showed that greater exposure to early-life pain adversely affects brain maturation and overall neurodevelopment in very preterm infants<sup>64</sup>. Consistent with these findings, neonatal invasive procedures have also been associated with altered white matter microstructure, which in turn correlates with poorer cognitive outcomes at school age among children born preterm<sup>65</sup>. Taken together, these findings support the behavioral and cognitive alterations observed in the present study and suggest that repeated painful stimulation during critical periods of brain development may disrupt neurodevelopmental processes. Early-life exposure to repeated nociceptive stress may therefore induce long-term alterations in cognitive, emotional and motor functions, reinforcing evidence from both experimental animal models and clinical human studies.

**Effects of Repeated Invasive Procedures on Responses to Painful Stimuli:** In the present study, preterm neonatal rats exposed to repeated invasive procedures demonstrated reduced behavioral responses to painful stimuli in later life, suggesting increased pain tolerance. This finding indicates that early repeated painful experiences may modulate neurophysiological mechanisms involved in pain perception and processing, potentially leading to an adaptive alteration in nociceptive responsiveness. These results suggest that repeated exposure to pain during the neonatal period may induce long-lasting changes in pain perception. Such adaptations may manifest as increased pain tolerance or hypo-responsiveness to noxious stimuli later in life, which may subsequently influence neurobehavioral development. Previous clinical studies support this interpretation. Grunau et al. reported that neonates exposed to greater numbers of procedural painful events exhibited reduced cortisol responses to stress at approximately 32 weeks of postmenstrual age. These long-term alterations have been suggested to arise from the heightened vulnerability of brain regions rich in glucocorticoid receptors, particularly the hippocampus and prefrontal cortex, to early-life stress exposure<sup>66</sup>.

**Effects of Repeated Invasive Procedures on Brain Histopathology;** In the present study, repeated invasive procedures during

the premature period resulted in increased apoptotic cell counts in several brain regions of neonatal rats. These histopathological alterations may contribute to persistent learning and memory impairments as well as long-term behavioral abnormalities observed later in life. Consistent with our findings, Anand et al. demonstrated in a neonatal rat model that repeated pain exposure significantly increases neuronal apoptosis<sup>36</sup>. Similarly, Ranger et al. reported that early exposure to repeated procedural pain has long-lasting effects on brain development extending into school age, with greater exposure to painful procedures in preterm infants being associated with reduced cortical thickness in the frontal and parietal lobes at seven years of age<sup>63</sup>. Lammertink et al. further showed that increased exposure to invasive procedures during the neonatal period delays structural connectivity maturation within limbic networks, including the hippocampus and amygdala, until term-equivalent age in preterm infants. Reduced connectivity within these limbic structures has been associated with increased behavioral problems during early childhood<sup>65</sup>. Repeated procedural pain is known to trigger oxidative stress and inflammatory responses, both of which may interfere with normal neurodevelopmental processes. These mechanisms can impair the maturation of premyelinating cells and disrupt myelination. Previous studies have indicated that pain-related stress during the neonatal period affects pre-oligodendrocytes cells that ensheath axons prior to differentiation into mature myelin-forming oligodendrocytes thereby increasing vulnerability of the developing brain<sup>67</sup>. Taken together, the present findings are consistent with experimental evidence demonstrating that both inflammatory pain and repeated injections promote apoptosis in the neonatal rat brain, supporting the hypothesis that early-life nociceptive stress may induce long-term structural and functional alterations in the developing nervous system.

## 6. Conclusion

The present study demonstrates that pain and stress induced by repeated invasive procedures during the premature period negatively affect early-life body weight gain in neonatal rats and are associated with increased anxiety-like, hyperactive, aggressive and competitive behaviors within the home cage environment. Notably, despite having unopened eyes during the early postnatal period, neonatal rats appeared capable of recognizing and retaining painful stimuli, exhibiting behavioral responses suggestive of early nociceptive memory formation. Exposure to repeated invasive procedures during the premature period resulted in long-term neurobehavioral alterations, including increased fear- and anxiety-related behaviors, impaired social interaction and reduced learning and memory performance in later life. In addition, decreased responsiveness to painful stimuli and impaired balance and motor coordination were observed. Histopathological findings further revealed increased apoptotic cell counts in the hippocampal CA1 region, dentate gyrus, parietal cortex and prefrontal cortex, suggesting that early-life nociceptive stress may contribute to structural alterations in brain regions critical for cognitive and behavioral regulation.

Overall, these findings indicate that repeated invasive procedures during critical stages of brain development may lead to persistent behavioral and cognitive alterations extending into later life. From a translational perspective, the results suggest that frequent invasive procedures performed in neonatal intensive care units may have potential long-term consequences for physical, behavioral and neurocognitive development in preterm

infants. Therefore, minimizing the number of invasive procedures whenever possible, ensuring effective and safe pain management strategies and increasing clinical awareness regarding both short- and long-term consequences of neonatal pain exposure may be essential for improving neurodevelopmental outcomes in this vulnerable population.

### 6.1. Limitations of the experimental model

One limitation of the present study is that stress hormone levels were not measured during the period of repeated invasive procedures. Assessment of corticosterone levels through blood sampling during the first 10 postnatal days could have provided additional insight into the physiological stress response associated with repeated nociceptive exposure. However, such measurements would have required the use of a larger number of neonatal animals and therefore hormonal analyses were not performed in the current study.

### 6.2. Conflicts of interest

The authors declare no conflict of interest.

### 6.3. Funding

This study was not funded by any organization or institution.

### 6.4. Acknowledgements

We would like to express our deepest gratitude to the animal laboratory keepers and technicians for their support of this project.

### 6.5. Ethics declarations

This study was conducted after obtaining ethical committee approval from the Dokuz Eylül University Local Ethics Committee for Animal Experiments, protocol number 09/2022.

## 7. References

- Howson CP, Kinney MV, McDougall L, et al. Born Too Soon: Preterm Birth Matters, 2013: 1-10.
- Fitzgerald M. The development of nociceptive circuits. *Nat Rev Neurosci*, 2005;6(7): 507-520.
- Fitzgerald M, Walker SM. Infant pain management: a developmental neurobiological approach. *Nat Clin Pr Neurol*, 2009;(5): 35-50.
- Andrews K, Fitzgerald M. The cutaneous withdrawal reflex in human neonates: sensitization, receptive fields and the effects of contralateral stimulation. *Pain*, 1994;(56): 95-101.
- Fitzgerald M, Millard C, McIntosh N. Cutaneous hypersensitivity following peripheral tissue damage in newborn infants and its reversal with topical anaesthesia. *PAIN*, 1989;39(1): 31.
- Grunau RE, Oberlander TF, Whitfield MF, et al. Demographic and Therapeutic Determinants of Pain Reactivity in Very Low Birth Weight Neonates at 32 Weeks' Postconceptional Age. *Pediatrics*, 2001;107(1): 105-112.
- Holsti L, Grunau RE, Oberlander TF, et al. Prior pain induces heightened motor responses during clustered care in preterm infants in the NICU. *Early Hum Dev*, 2005;81(3): 293-302.
- Holsti L, Grunau RE, Whitfield MF, et al. Behavioral Responses to Pain Are Heightened After Clustered Care in Preterm Infants Born Between 30 and 32 Weeks Gestational Age. *Clin J Pain*, 2006;22(9): 757.
- Ranger M, Johnston CC, Anand KJS. Current Controversies Regarding Pain Assessment in Neonates. *Semin Perinatol*, 2007;31(5): 283-288.
- van Dijk M, Tibboel D. Update on pain assessment in sick neonates and infants. *Pediatr Clin North Am*, 2012;(59): 1167-1181.
- Carbajal R, Lenclen R, Jugie M, et al. Morphine does not provide adequate analgesia for acute procedural pain among preterm neonates. *Pediatrics*, 2005;115(6): 1494-1500.
- Johnston C, Barrington KJ, Taddio A, et al. Pain in Canadian NICUs: have we improved over the past 12 years? *Clin J Pain*, 2011;27(3): 225-232.
- Chrousos GP. Stress and disorders of the stress system. *Nat Rev Endocrinol*, 2009;5(7): 374-381.
- Coplan JD, Andrews MW, Rosenblum LA, et al. Persistent elevations of cerebrospinal fluid concentrations of corticotropin-releasing factor in adult nonhuman primates exposed to early-life stressors: implications for the pathophysiology of mood and anxiety disorders. *Proc Natl Acad Sci*, 1996;93(4): 1619-1623.
- Lupien SJ, McEwen BS, Gunnar MR, et al. Effects of stress throughout the lifespan on the brain, behaviour and cognition. *Nat Rev Neurosci*, 2009;10(6): 434-445.
- Peters KL. Neonatal stress reactivity and cortisol. *J Perinat Neonatal Nurs*, 1998;(11): 45-59.
- Meaney MJ, Diorio J, Francis D, et al. Early environmental regulation of forebrain glucocorticoid receptor gene expression: Implications for adrenocortical responses to stress. *Dev Neurosci*, 1996;18: 49-72.
- McEwen BS. Protection and damage from acute and chronic stress: allostasis and allostatic overload and relevance to the pathophysiology of psychiatric disorders. *Ann N Acad Sci*, 2004;(1032): 1-7.
- Volpe JJ. Brain injury in premature infants: a complex amalgam of destructive and developmental disturbances. *Lancet Neurol*, 2009;8(1): 110-124.
- Kostović I, Judaš M, Radoš M, et al. Laminar Organization of the Human Fetal Cerebrum Revealed by Histochemical Markers and Magnetic Resonance Imaging. *Cereb Cortex*, 2002;12(5): 536-544.
- Kostović I, Judaš M. Correlation between the sequential ingrowth of afferents and transient patterns of cortical lamination in preterm infants. *Anat Rec*, 2002;267(1): 1-6.
- McQuillen PS, Ferriero DM. Perinatal subplate neuron injury: implications for cortical development and plasticity. *Brain Pathol*, 2005;(15): 250-260.
- Qu Y, Vadivelu S, Choi L, et al. Neurons derived from embryonic stem (ES) cells resemble normal neurons in their vulnerability to excitotoxic death. *Exp Neurol*, 2003;184(1): 326-336.
- McDonald JW, Johnston MV. Physiological and pathophysiological roles of excitatory amino acids during central nervous system development. *Brain Res Brain Res Rev*, 1990;(15): 41-70.
- Talos DM, Follett PL, Folkerth RD, et al. Developmental regulation of AMPA receptor subunit expression in forebrain and relationship to regional susceptibility to hypoxic/ischemic injury: Part II. Human cerebral white matter and cortex. *J Comp Neurol*, 2006;497(1): 61-77.
- Deng W, Rosenberg PA, Volpe JJ, et al. Calcium-permeable AMPA/kainate receptors mediate toxicity and preconditioning by oxygen-glucose deprivation in oligodendrocyte precursors. *Proc Natl Acad Sci*, 2003;100(11): 6801-6806.
- Back SA, Gan X, Li Y, et al. Maturation-dependent vulnerability of oligodendrocytes to oxidative stress-induced death caused by glutathione depletion. *J Neurosci Off J Soc Neurosci*, 1998;18(16): 6241-6253.
- Back SA, Luo NL, Mallinson RA, et al. Selective vulnerability of preterm white matter to oxidative damage defined by F2-isoprostanes. *Ann Neurol*, 2005;(58): 108-120.
- Haynes RL, Folkerth RD, Keefe RJ, et al. Nitrosative and oxidative injury to premyelinating oligodendrocytes in periventricular leukomalacia. *J Neuropathol Exp Neurol*, 2003;(62): 441-450.
- Buntinx M, Moreels M, Vandenabeele F, et al. Cytokine-induced cell death in human oligodendroglial cell lines: I. Synergistic effects of IFN- $\gamma$  and TNF- $\alpha$  on apoptosis. *J Neurosci Res*, 2004;76(6): 834-845.

31. Pang Y, Cai Z, Rhodes PG. Effect of tumor necrosis factor- $\alpha$  on developing optic nerve oligodendrocytes in culture. *J Neurosci Res*, 2005;80(2): 226-234.
32. Slater L, Asmerom Y, Boskovic DS, et al. Procedural pain and oxidative stress in premature neonates. *J Pain*, 2012;(13): 590-597.
33. Hansson E. Could chronic pain and spread of pain sensation be induced and maintained by glial activation? *Acta Physiol*, 2006;(187): 321-327.
34. Brummelte S, Grunau RE, Chau V, et al. Procedural pain and brain development in premature newborns. *Ann Neurol*, 2012;71(3): 385-396.
35. Smith GC, Gutovich J, Smyser C, et al. Neonatal intensive care unit stress is associated with brain development in preterm infants. *Ann Neurol*, 2011;(70): 541-549.
36. Anand KJS, Garg S, Rovnaghi CR, et al. Ketamine Reduces the Cell Death Following Inflammatory Pain in Newborn Rat Brain. *Pediatr Res*, 2007;62(3): 283-290.
37. Duhrsen L, Simons SH, Dzyetko M, et al. Effects of repetitive exposure to pain and morphine treatment on the neonatal rat brain. *Neonatology*, 2013;(103): 35-43.
38. Zwicker JG, Grunau RE, Adams E, et al. Score for neonatal acute physiology-II and neonatal pain predict corticospinal tract development in premature newborns. *Pediatr Neurol*, 2013;(48): 123-129.
39. Ranger M, Chau CMY, Garg A, et al. Neonatal Pain-Related Stress Predicts Cortical Thickness at Age 7 Years in Children Born Very Preterm. *PLOS ONE*, 2013;8(10): 76702.
40. Doesburg SM, Chau CM, Cheung TPL, et al. Neonatal pain-related stress, functional cortical activity and visual-perceptual abilities in school-age children born at extremely low gestational age. *Pain*, 2013;154(10): 1946-1952.
41. Vinall J, Grunau RE. Impact of repeated procedural pain-related stress in infants born very preterm. *Pediatr Res*, 2014;75(5): 5584-5591.
42. Carbajal R, Rousset A, Danan C, et al. Epidemiology and treatment of painful procedures in neonates in intensive care units. *JAMA J Am Med Assoc*, 2008;300(1): 60-70.
43. Cruz MD, Fernandes AM, Oliveira CR. Epidemiology of painful procedures performed in neonates: A systematic review of observational studies. *Eur J Pain*, 2016;20(4): 489-498.
44. Burnett AC, Cheong JLY, Doyle LW. Biological and Social Influences on the Neurodevelopmental Outcomes of Preterm Infants. *Clin Perinatol*, 2018;45(3): 485-500.
45. Grunau RE, Whitfield MF, Petrie-Thomas J, et al. Neonatal pain, parenting stress and interaction, in relation to cognitive and motor development at 8 and 18 months in preterm infants. *Pain*. 2009;143(1):138-146.
46. Vinall J, Miller SP, Synnes AR, et al. Parent behaviors moderate the relationship between neonatal pain and internalizing behaviors at 18 months corrected age in children born very prematurely. *PAIN®*, 2013;154(9): 1831-1839.
47. Sengupta P. The Laboratory Rat: Relating Its Age With Human's. *Int J Prev Med*, 2013;4(6): 624-630.
48. Hatfield LA, Murphy N, Karp K, et al. A Systematic Review of Behavioral and Environmental Interventions for Procedural Pain Management in Preterm Infants. *J Pediatr Nurs*, 2019;44: 22-30.
49. Shen Q, Leng H, Shi Y, Chen Y, Zheng X. A protocol to develop a standard guideline for neonatal pain management. *Transl Pediatr*, 2021;10(6): 6.
50. Nguyen AT, Armstrong EA, Yager JY. Neurodevelopmental Reflex Testing in Neonatal Rat Pups. *J Vis Exp*, 2017;24(122): 55261.
51. Feather-Schussler DN, Ferguson TS. A Battery of Motor Tests in a Neonatal Mouse Model of Cerebral Palsy. *J Vis Exp JoVE*, 2016;(117): 53569.
52. Seibenhener ML, Wooten MC. Use of the Open Field Maze to measure locomotor and anxiety-like behavior in mice. *J Vis Exp JoVE*, 2015;(96): 52434.
53. Kraeuter AK, Guest PC, Sarnyai Z. The Open Field Test for Measuring Locomotor Activity and Anxiety-Like Behavior. *Methods Mol Biol Clifton NJ*, 2019;1916: 99-103.
54. Buccafusco JJ. *Methods of Behavior Analysis in Neuroscience*. 2nd ed. CRC Press/Taylor & Francis, 2009.
55. Kondrakiewicz K, Kostecki M, Szadzińska W, et al. Ecological validity of social interaction tests in rats and mice. *Genes Brain Behav*, 2019;18(1): 12525.
56. D'Amour FE. A method for determining loss of pain sensation. *J Pharmacol Exp Ther*, 1941;(72): 74-78.2.
57. Afolabi AO, Alagbonsi IA, Aliyu JA. Pharmacological mechanisms involved in the analgesia induced by ethanol extract of *Hybanthus enneaspermus* leaves. *J Pain Res*, 2017;(10): 1997-2002.
58. Hunskar S, Hole K. The formalin test in mice: dissociation between inflammatory and non-inflammatory pain. *Pain*, 1987;(30): 103-114.
59. Castellano C, Puglisi-Allegra S, Renzi P, et al. Genetic differences in daily rhythms of pain sensitivity in mice. *Pharmacol Biochem Behav*, 1985;23(1): 91-92.
60. Allbutt HN, Henderson JM. Use of the narrow beam test in the rat, 6-hydroxydopamine model of Parkinson's disease. *J Neurosci Methods*, 2007;159(2): 195-202.
61. Vinall J, Miller SP, Bjornson BH, et al. Invasive procedures in preterm children: brain and cognitive development at school age. *Pediatrics*, 2014;133(3): 412-421.
62. Ranger M, Zwicker JG, Chau CMY, et al. Neonatal Pain and Infection Relate to Smaller Cerebellum in Very Preterm Children at School Age. *J Pediatr*, 2015;167(2): 292-298.
63. Cook KM, De Asis-Cruz J, Kim JH, et al. Experience of early-life pain in premature infants is associated with atypical cerebellar development and later neurodevelopmental deficits. *BMC Med*, 2023;21(1): 435.
64. Selvanathan T, Miller SP. Brain health in preterm infants: importance of early-life pain and analgesia exposure. *Pediatr Res*, 2024;96(6): 1397-1403.
65. Lammertink F, Benders MJNL, Hermans EJ, et al. Vulnerability of the Neonatal Connectome following Postnatal Stress. *J Neurosci Off J Soc Neurosci*, 2022;42(48): 8948-8959.
66. Grunau RE, Haley DW, Whitfield MF, et al. Altered Basal Cortisol Levels at 3, 6, 8 and 18 Months in Infants Born at Extremely Low Gestational Age. *J Pediatr*, 2007;150(2): 151-156.
67. Qu Y, Vadivelu S, Choi L, et al. Neurons derived from embryonic stem (ES) cells resemble normal neurons in their vulnerability to excitotoxic death. *Exp Neurol*, 2003;184(1): 326-336.